



**SUBMITTAL
HUB & SPIGOT BI-SEAL GASKET**

6200 Rue Principale Sainte-Croix, Quebec G0S-2H0

BIBBY-STE-CROIX

Date	
Project	
Engineer	
Mechanical Contractor	

Hub & Spigot Pipe and Fittings for the Self-Locking "Bi-Seal" EPDM Gaskets

"Bi-Seal" provides a positive compression seal between hub and spigot at three separate points.

"Bi-Seal" is easy to install without complicated tools.

"Bi-Seal" will absorb marked deflection after assembly without leaking.

"Bi-Seal" will handle both residential and industrial wastes.

"Bi-Seal" is made to CSA B70 specifications for use with Bibby-Ste-Croix Hub and Spigot Pipe and Fittings.

S4001, Bi-Seal Gaskets for 2" (50 mm) through 15" (375 mm)

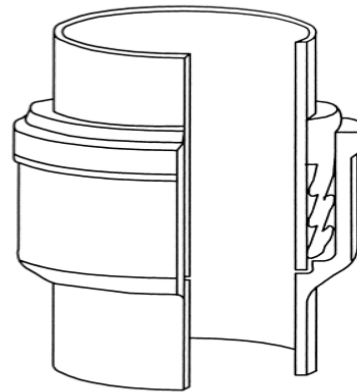

Bi-Seal Compression Joints – Series 4001

Code	Size	Qty per Box	Weight / Box
s 29020	in. 2 mm 50	50	10.0 lb. 4.5 kg
s 29030	in. 3 mm 75	50	20.0 lb. 9.0 kg
s 29040	in. 4 mm 100	50	35.0 lb. 15.9 kg
s 29050	in. 5 mm 125	–	–
s 29060	in. 6 mm 150	25	22.5 lb. 10.2 kg
s 29080	in. 8 mm 200	10	15.0 lb. 6.8 kg
s 29100	in. 10 mm 250	8	19.2 lb. 8.7 kg
s 29120	in. 12 mm 300	6	22.2 lb. 10.1 kg
s 29150	in. 15 mm 375	6	30.6 lb. 13.9 kg

